

ControlMySpa™

Retrofit User Guide:

Adding a CMS™ GATEWAY ULTRA to an existing spa





TABLE OF CONTENTS

CONTROLMYSPA™ SYSTEM OVERVIEW 01	3
CONTROLMYSPA™ ESSENTIAL INFO 02	4
CMS™ GATEWAY INSTALLATION GUIDE 03	5
CMS™ ACCOUNT SETUP: SPA CONNECTION 04	15
SETTING UP THE CONTROLMYSPA™ APP 05	18
CONTROLMYSPA™ WEBSITE – SPA OWNER OVERVIEW 08	26
INFORMATION MENU 09	29

ControlMySpa™ was built to provide the Spa Professionals with real-time access to the tub so you will think you are actually standing next to it. And, for your Customer, peace of mind, new app features, the ability to schedule events and equip smart heating so your spa is ready to go when you are.

WELCOME TO CONTROLMYSPA™

Overview

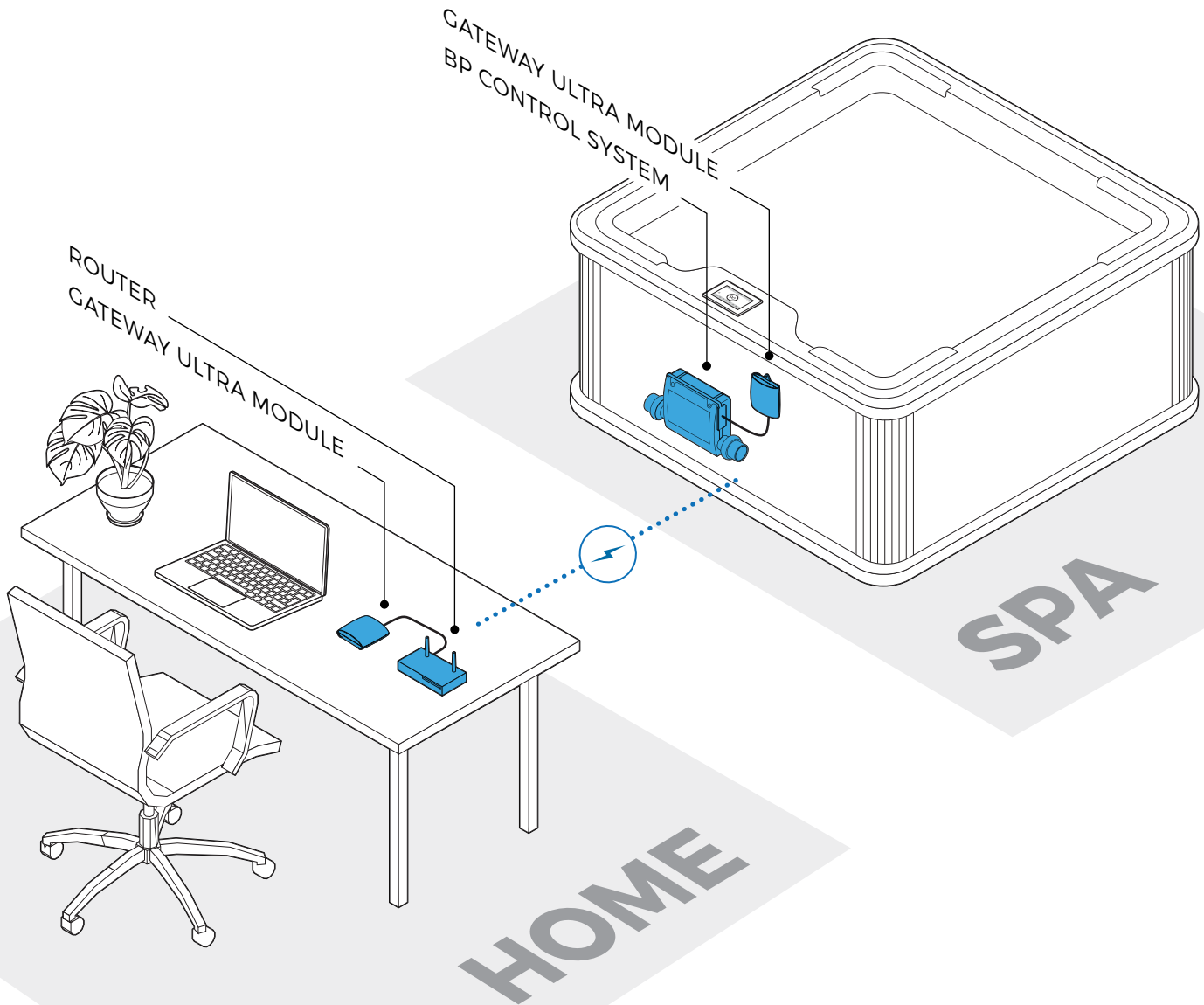

ControlMySpa™

CMS™ SYSTEM CONSISTS OF:



WEBSITE

ControlMySpa™ website with Login and access to spas

CMST™ GATEWAY ULTRA Modules



Home Module



Spa Module

www.balboawater.com/GatewayUltra

SMARTPHONE | TABLET



iOS (Apple) ControlMySpa™ mobile app and/or Android ControlMySpa™ Mobile app

The ControlMySpa™ system consists of:

- ControlMySpa™ Gateway installed on a spa/Hot Tub
- iOS (Apple) ControlMySpa™ mobile app or Android ControlMySpa™ mobile app
- ControlMySpa™ website with log-in and access to spas

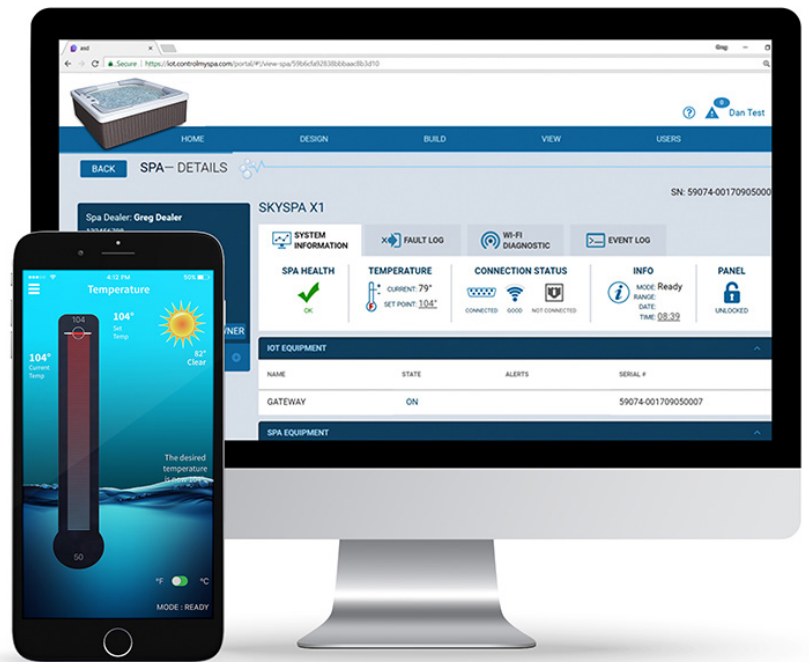

The ControlMySpa™ Logins:

- The iOS or Android ControlMySpa™ apps can only be accessed with an owner log-in
- The ControlMySpa™ website can be accessed with an owner log-in.

ControlMySpa™

GATEWAY ULTRA INSTALLATION GUIDE

ControlMySpa™

GATEWAY ULTRA Hardware Connections

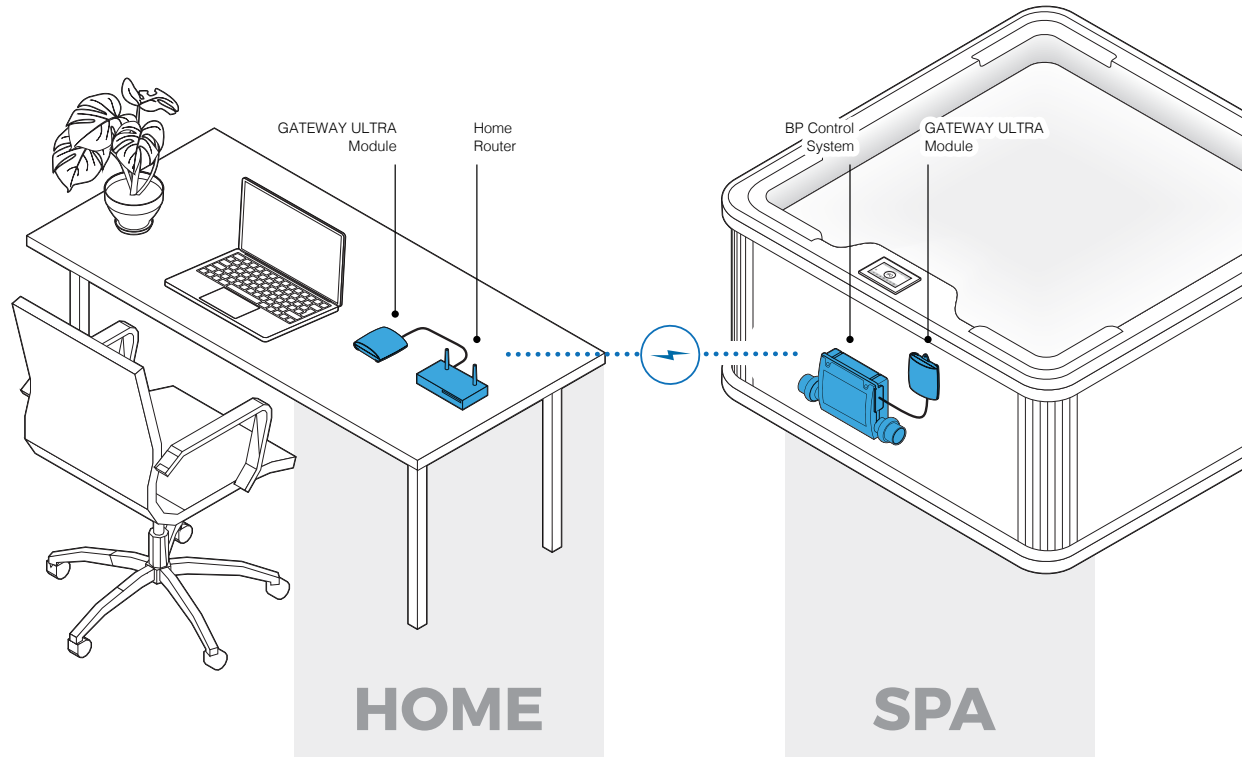

GATEWAY ULTRA Module (side view)

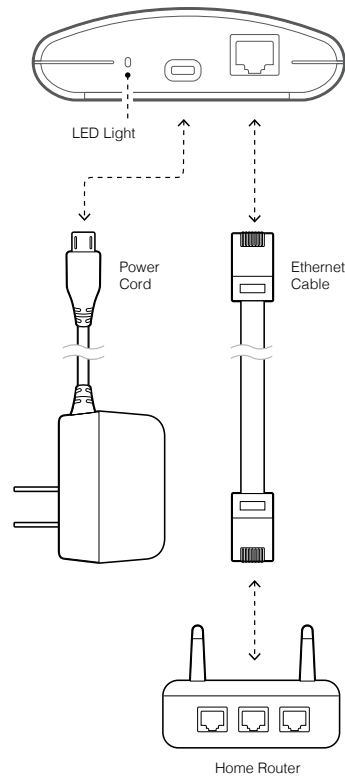

GATEWAY ULTRA Module (side view)

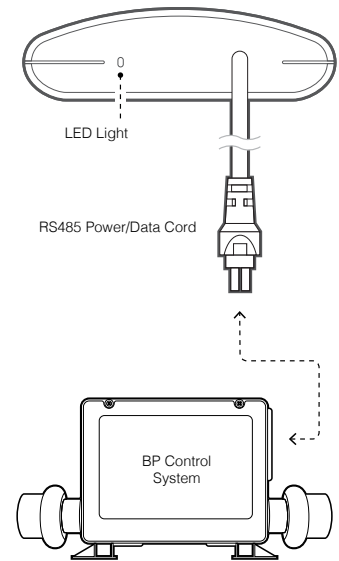

ControlMySpa™

Connect GATEWAY ULTRA hardware in your home

Step 1

Plug the supplied ethernet cable into the home router (A).

Step 2

Plug the other end of the ethernet cable into the GATEWAY ULTRA module (B).

Step 3

Plug the supplied power cord into the GATEWAY ULTRA module (C).

Step 4

Plug the other end of the supplied power cord into wall power (D).





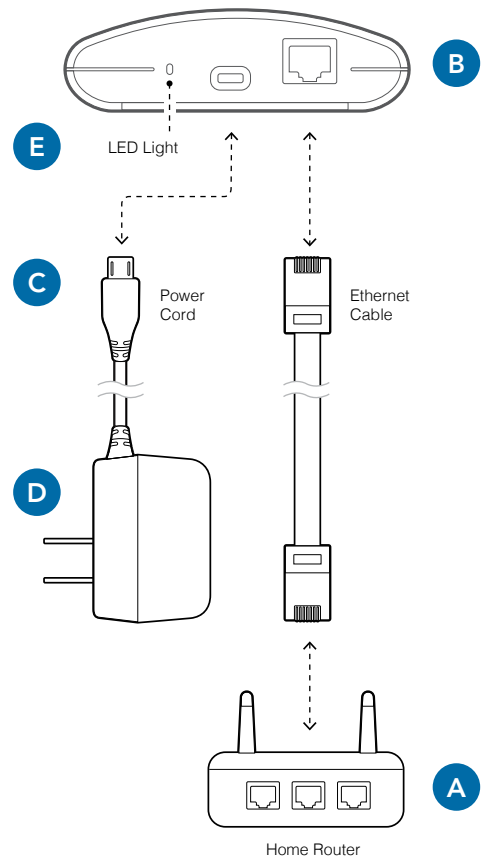

GATEWAY ULTRA Module (side view)



LED Light Chart (E)

This chart applies to the home and spa GATEWAY ULTRA modules.

-  Red - Solid: The GATEWAY ULTRA and the spa are not connected.
-  Red - Blinking: Home and spa GATEWAY ULTRA modules are connected, but no connection to the spa controller.
-  Blue - Blinking: Remote software update is underway. Do not unplug power.
-  Green - Blinking: CMS™ GATEWAY ULTRA spa and home modules RF is connected, but no connection to internet.
-  Green - Solid: Spa successfully connected to internet. No errors.



STOP!

Warning: All high voltage electrical work should only be performed by a trained and licensed electrician. All electrical work performed should comply with national and local electrical codes and regulations applicable for the location of the Spa.

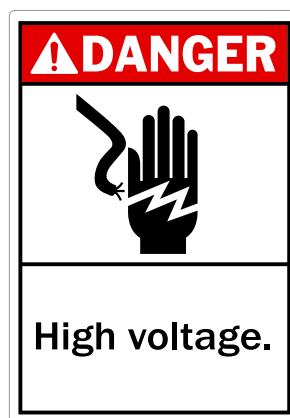

CONTROLMYSPA™ GATEWAY ULTRA INSTALLATION ON SPA

PLAN FOR SET-UP:

Although the GATEWAY ULTRA module can be mounted anywhere in the spa and function properly, for best possible reception and range, the GATEWAY ULTRA module should be mounted in the spa as high up in the spa as is reasonable.

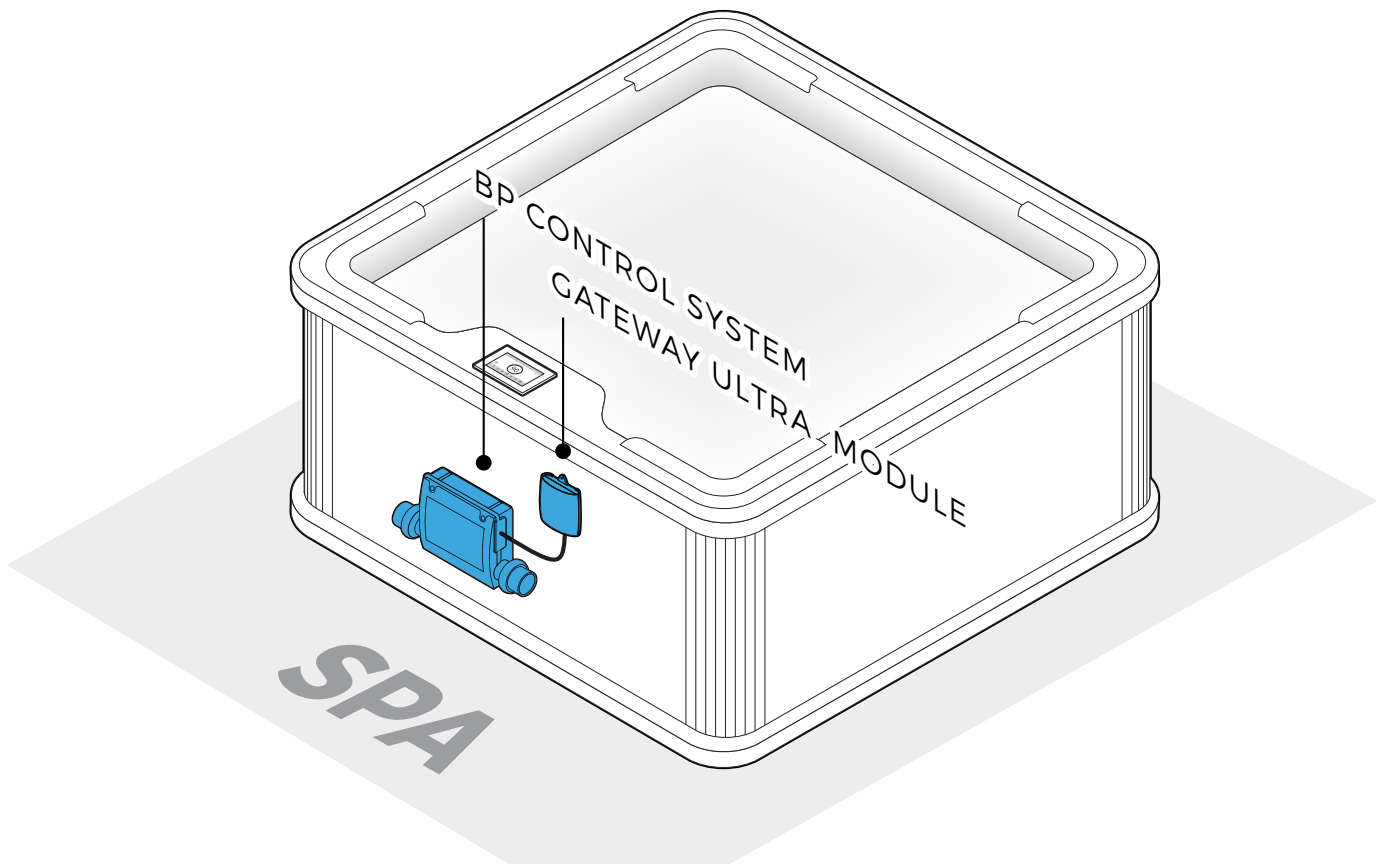

ControlMySpa™

GATEWAY ULTRA Installation on Spa

Step 1

Ensure All Power is Disconnected to Spa

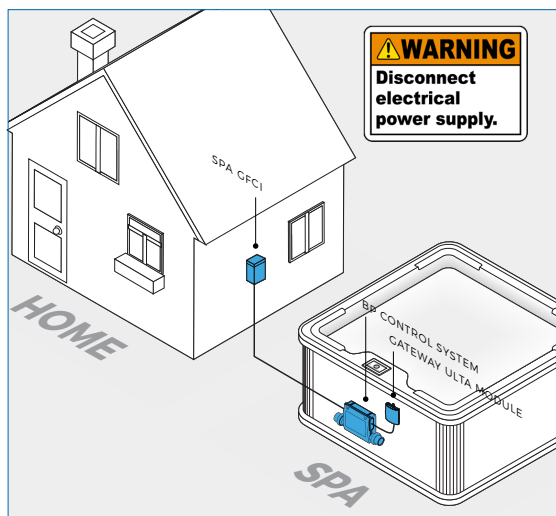

Warning:

WARNING: All high voltage electrical work should only be performed by a trained and licensed electrician. All electrical work performed should comply with national and local electrical codes and regulations applicable for the location of the Spa.

Step 2

Ensure The Spa Controller is made by Balboa Water Group (BWG)

Ways to tell if the spa controller is from Balboa Water Group

The Control System Serial Number has “Balboa” on it

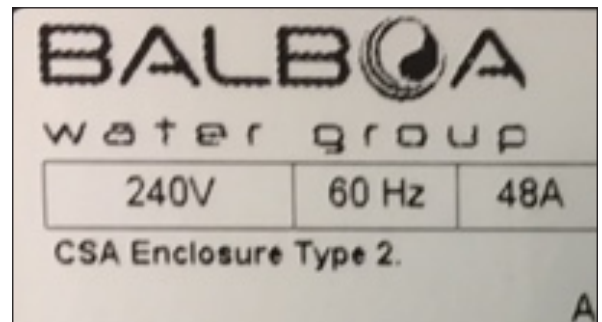

The Control System PCBA has “Balboa” on it



NOTE: If your spa does not have a Control System made by Balboa Water Group (BWG), then ControlMySpa cannot be used.

ControlMySpa™

GATEWAY ULTRA Installation on Spa

Step 3: Ensure The Spa Controller is a BP Series Spa Control System

Ways to Tell if the Spa Controller is a BP Series Spa Control System:



Control System

A.

The Control System Enclosure Sticker has “BP” on it. Note: Not all BP Enclosure Stickers have “BP” on them, but many do.

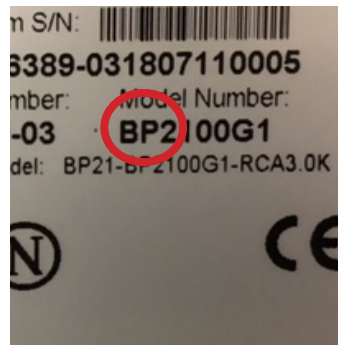

Serial Number

B.

The Control System Serial Number has a “BP” in the model number. Note: Not all BP Serial Numbers have “BP” in the model number, but many do.

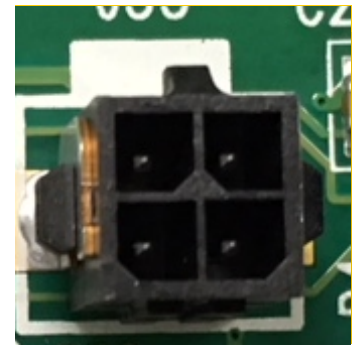

PC Board

C.

The Control System PC Board has Four Pin Molex Female Connectors. Only BP Control Systems from Balboa Water Group have these connectors on the PC Board, and all BP Systems must have them.

NOTE: If your spa does not have a BP Control System, then ControlMySpa™ cannot be used.

STEP 4

Using a Screw Driver, Remove the Enclosure Cover from the BP Control System in your Spa



STEP 5

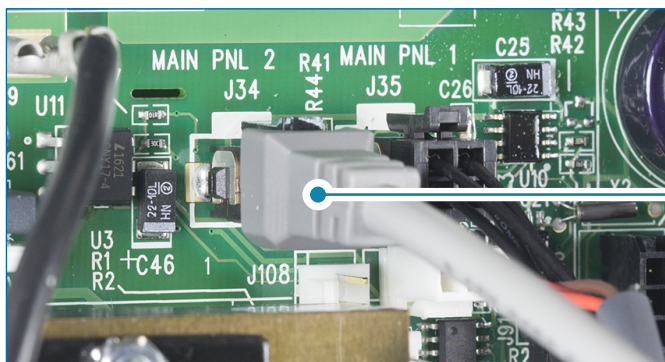

Connect low voltage cable from Gateway to BP Spa Controller

Connect the low voltage RS485 cable to the spa data bus. The 4-pin connector connects to any available panel port, or to a splitter already connected to a panel port. Please make sure you connect in the correct plug orientation.

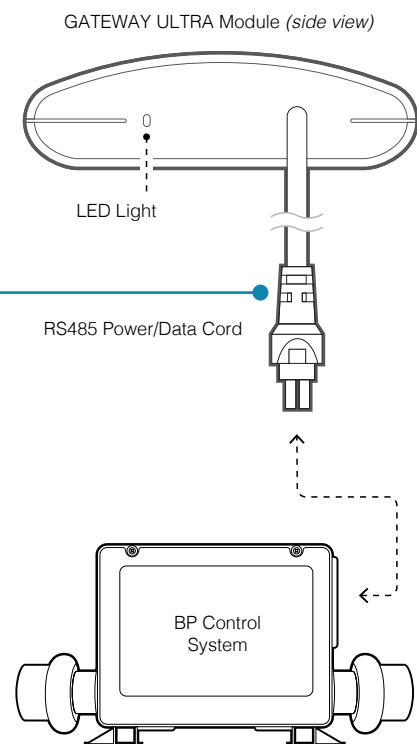

CONTROLMYSPA™ GATEWAY ULTRA INSTALLATION ON SPA

STEP 6

Mount the GATEWAY ULTRA module inside your spa as high up as possible and away from other metal components.

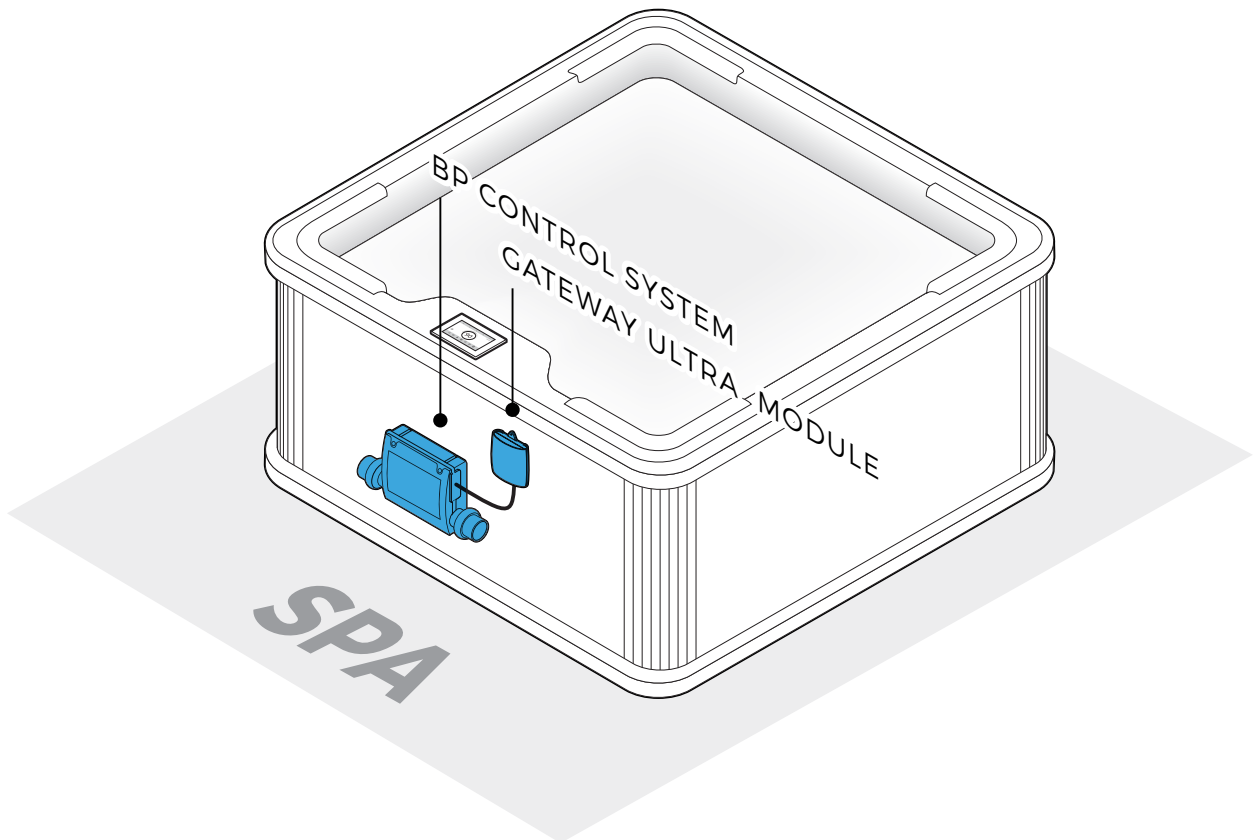

STEP 7

Using a Screw Driver, firmly re-attached the enclosure cover to the BP Control System in your Spa



STEP 8

Turn on power to Spa

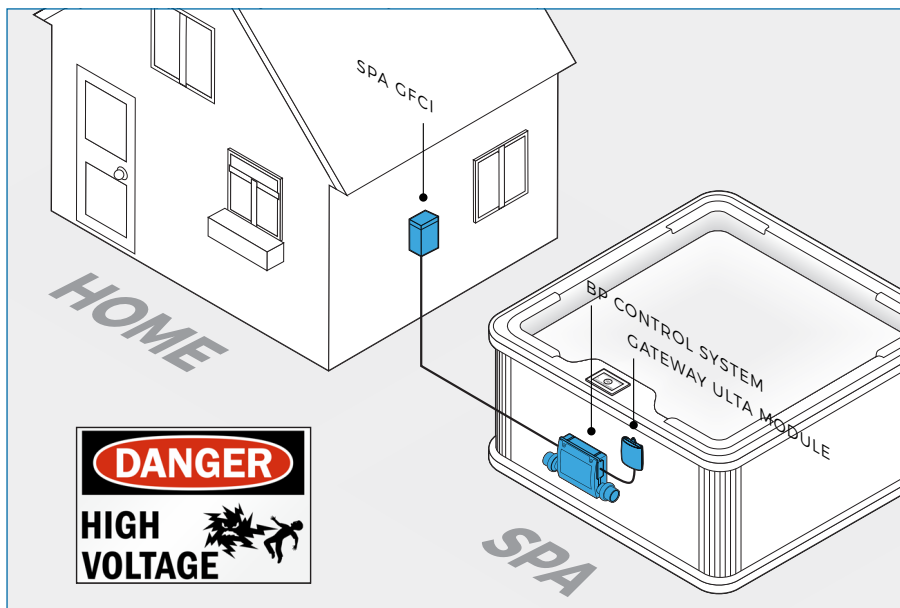

ControlMySpa™

ACCOUNT SETUP AND SPA CONNECTION

ControlMySpa™ App for the smart device

FOR IPHONE® OR IPAD® (IOS/APPLE)

Search the Apple iOS App Store for
“controlmyspa”

Or Use this link: <https://goo.gl/j31t1V>



FOR ANDROID® PHONES/TABLETS

Search Google Play App Store for
“controlmyspa”

Or Use this link: <https://goo.gl/CG4Yci>



**Control your tub
from your smart device.**

ControlMySpa™

CMS™ Code Information

WHAT IS A CMS™ CODE?

- CMS™ Code is an 8 digit letter/number combination that all Spa owners must have to use spas equipped with the ControlMySpa™ system
- Spa owners will need this CMS™ code to setup and connect their spas in the ControlMySpa™ database.
- The CMS™ code connects your spa to your OEM and Dealer for service and support

EXAMPLE CMS™ Code: ABC-12345

ABC = 3 letter code unique to each spa Manufacturer or OEM

12345 = 5 number code unique to each spa Dealer or Distributor

Note:

If you do not have a CMS™ Code, contact Your Spa Dealer or the Company that sold you the Gateway for Retrofit on your existing spa.

ControlMySpa™

Setup Spa Owner User Account

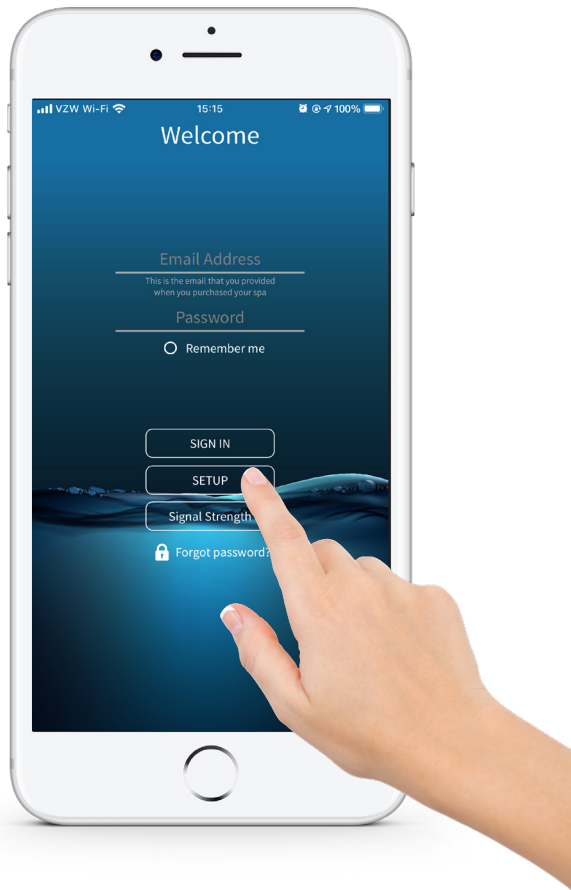

1. Open the app on your smart device

Press "SETUP" on the app.



2. Press "Next"

Confirm Bluetooth is ON in the iOS Settings.

ControlMySpa™

Setup Spa Owner User Account

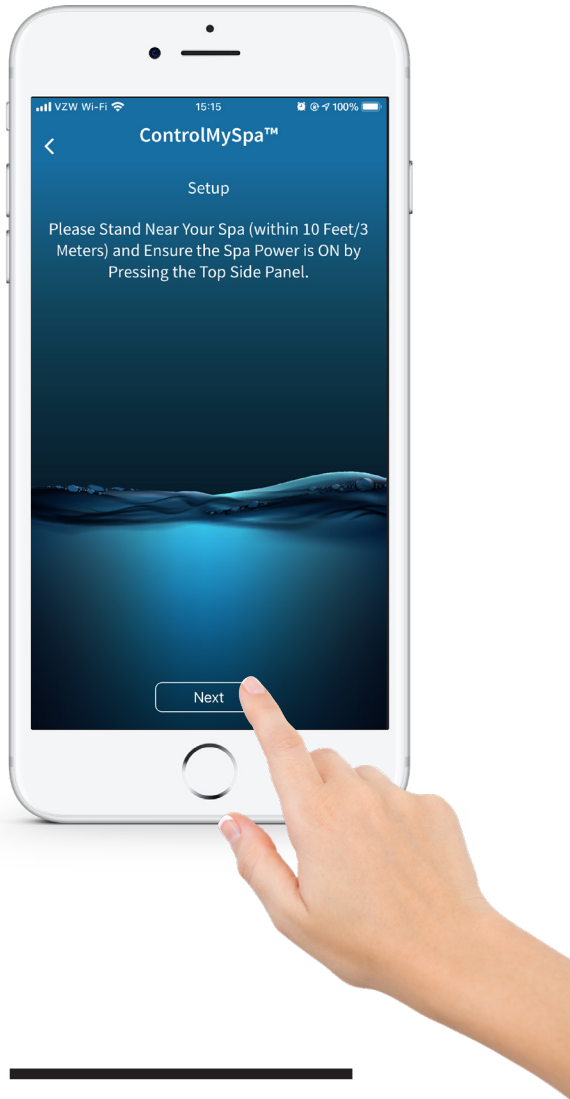

3. Press "Next"

Stand near your spa (within 10 feet/3 meters) and ensure the spa power in ON by pressing the topside panel. If the spa is powered ON, press "Next".

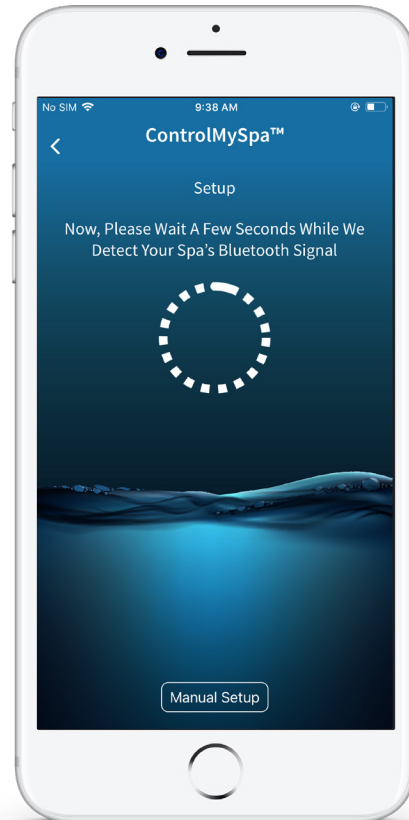

4. Detect Bluetooth

ControlMySpa™

Setup Spa Owner User Account



5. Press “Yes”

The serial number in the app should match the serial number on the back of the spa module.

6. Press “Next”

The CMS code is provided by your Dealer. Press “Next”.

ControlMySpa™

Setup Spa Owner User Account

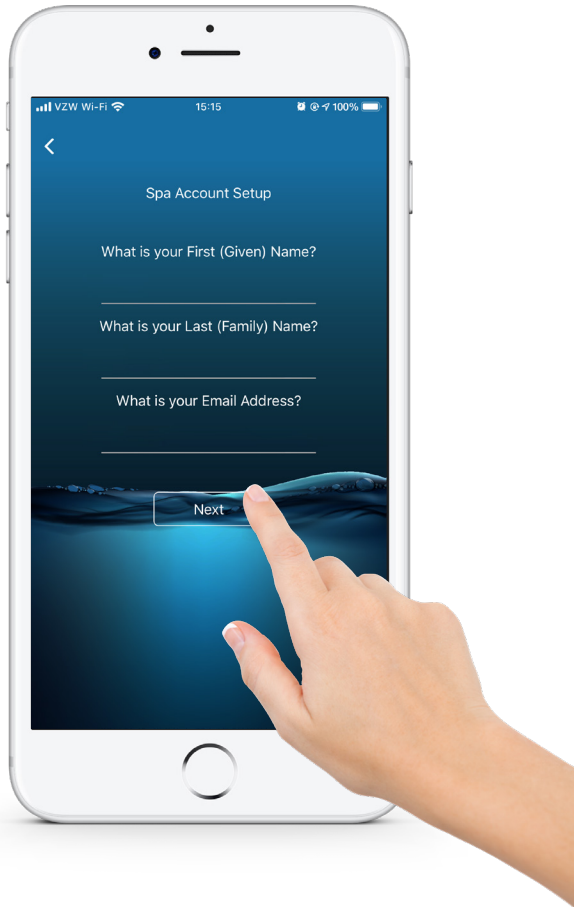

7.

Press “Next”

Input information and press “Next”.

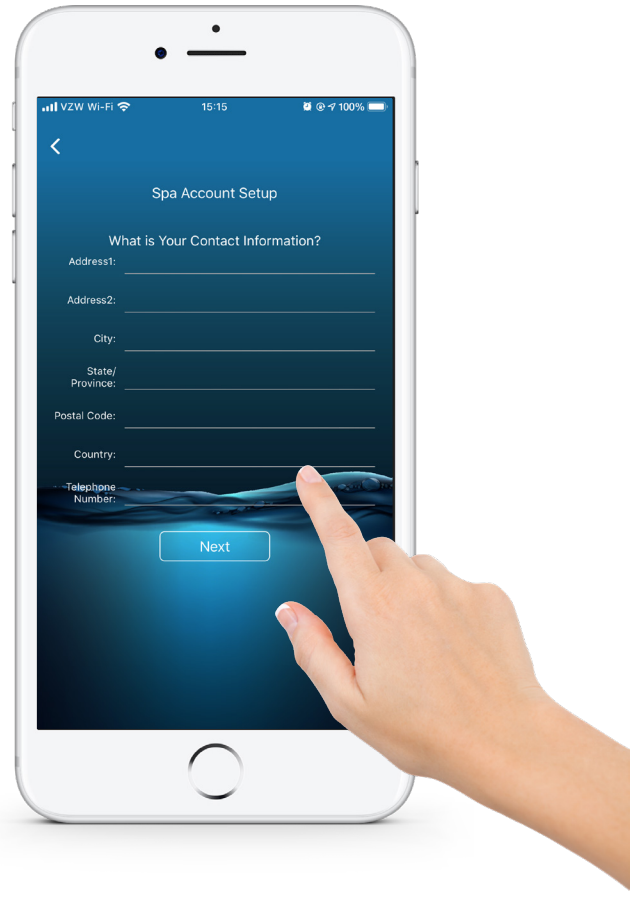

8.

Press “Next”

Input information and press “Next”.

ControlMySpa™

Setup Spa Owner User Account

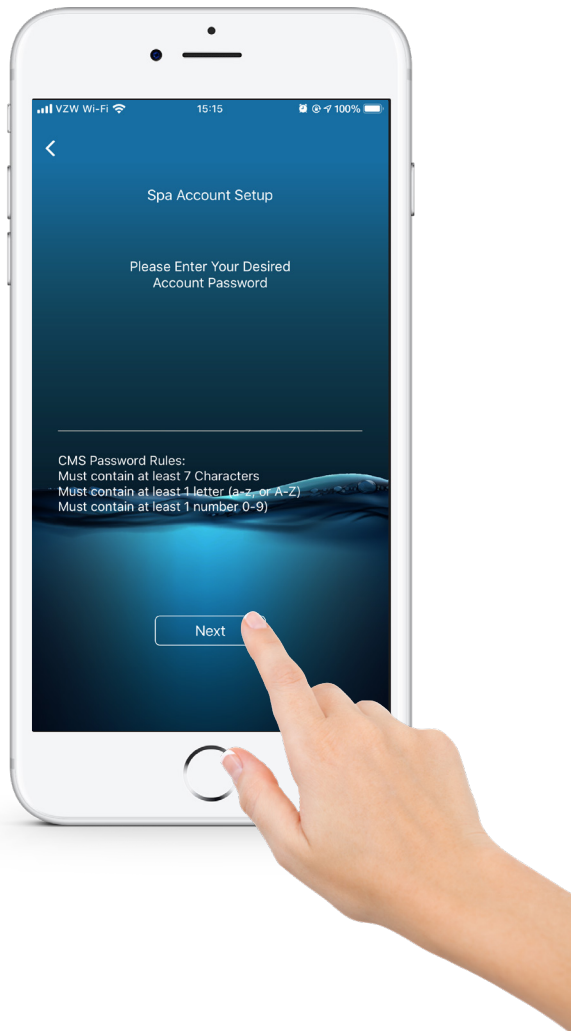

9. Press "Next"

Input information and press "Next".



10. Press "Next"

Your UserID and password will appear. Press "Next".

ControlMySpa™

Setup Spa Owner User Account

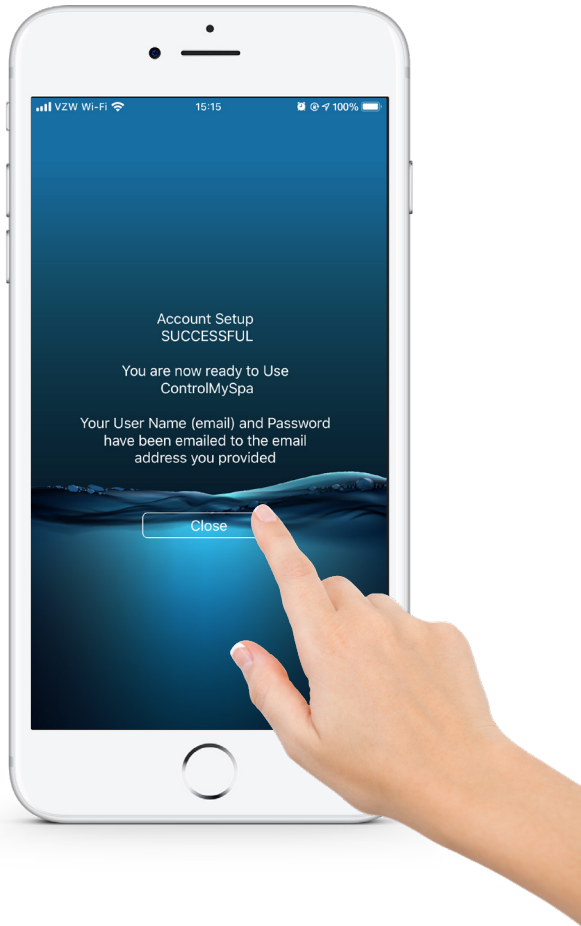

-
- 11.**
Press "Close"



-
- 12.**
Press "SIGN IN"

Input your email address, password and press "SIGN IN".

ControlMySpa™

Setup Spa Owner User Account

SUCCESS! YOUR ACCOUNT IS SETUP, AND YOU CAN CONTROL YOUR SPA WITH THE CMS APP.

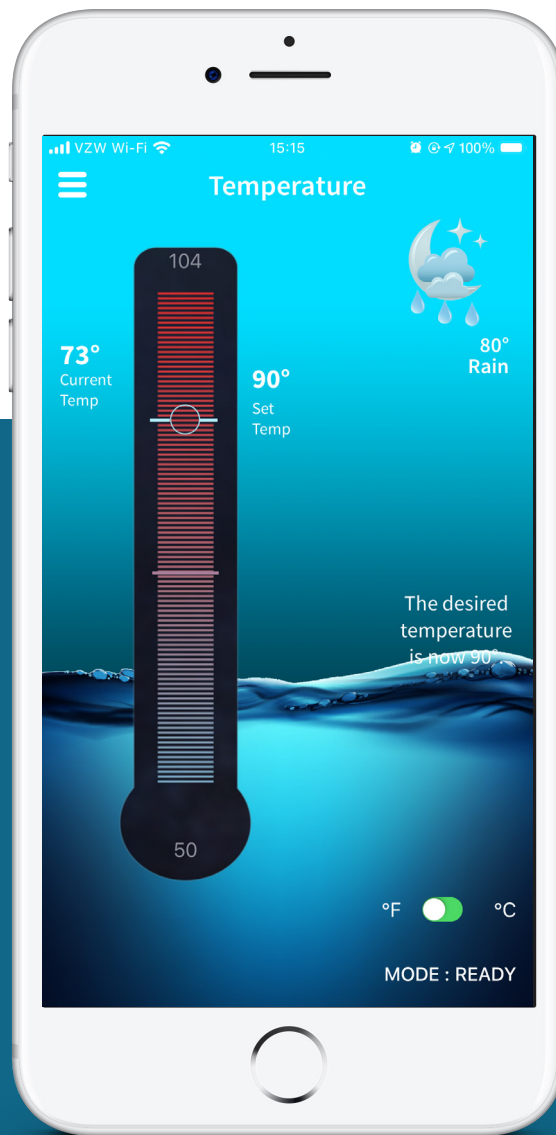

ControlMySpa™ Spa Owner Account Password

THE USER ACCOUNT EMAIL WILL RECEIVE AN AUTOMATED EMAIL:

At the e-mail address provided in the set-up, this email provides the new user their **LOG-IN** and **PASSWORD**.

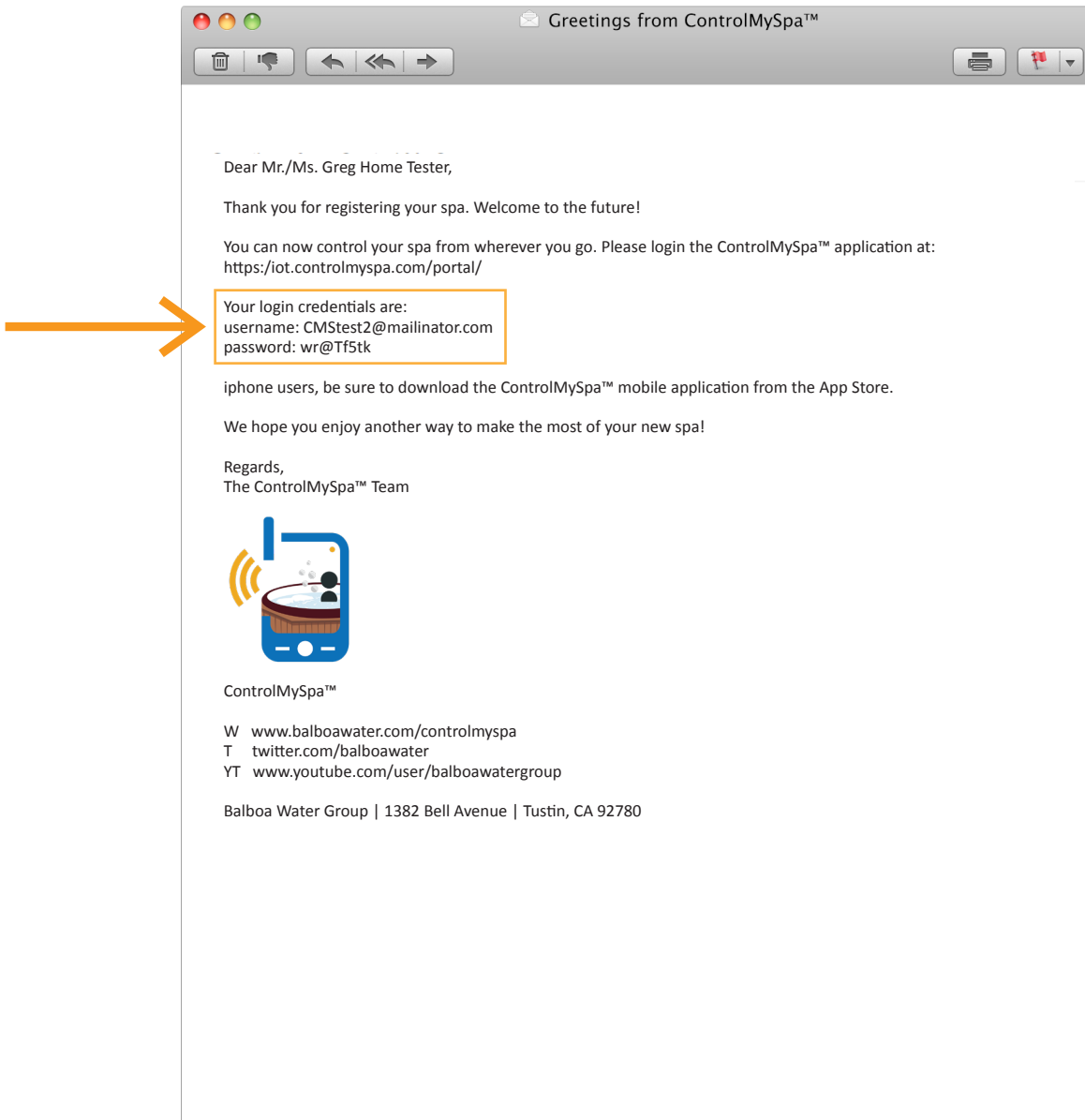

ControlMySpa™ Website Overview

SPA OWNER

ControlMySpa™

Spa Owner Overview

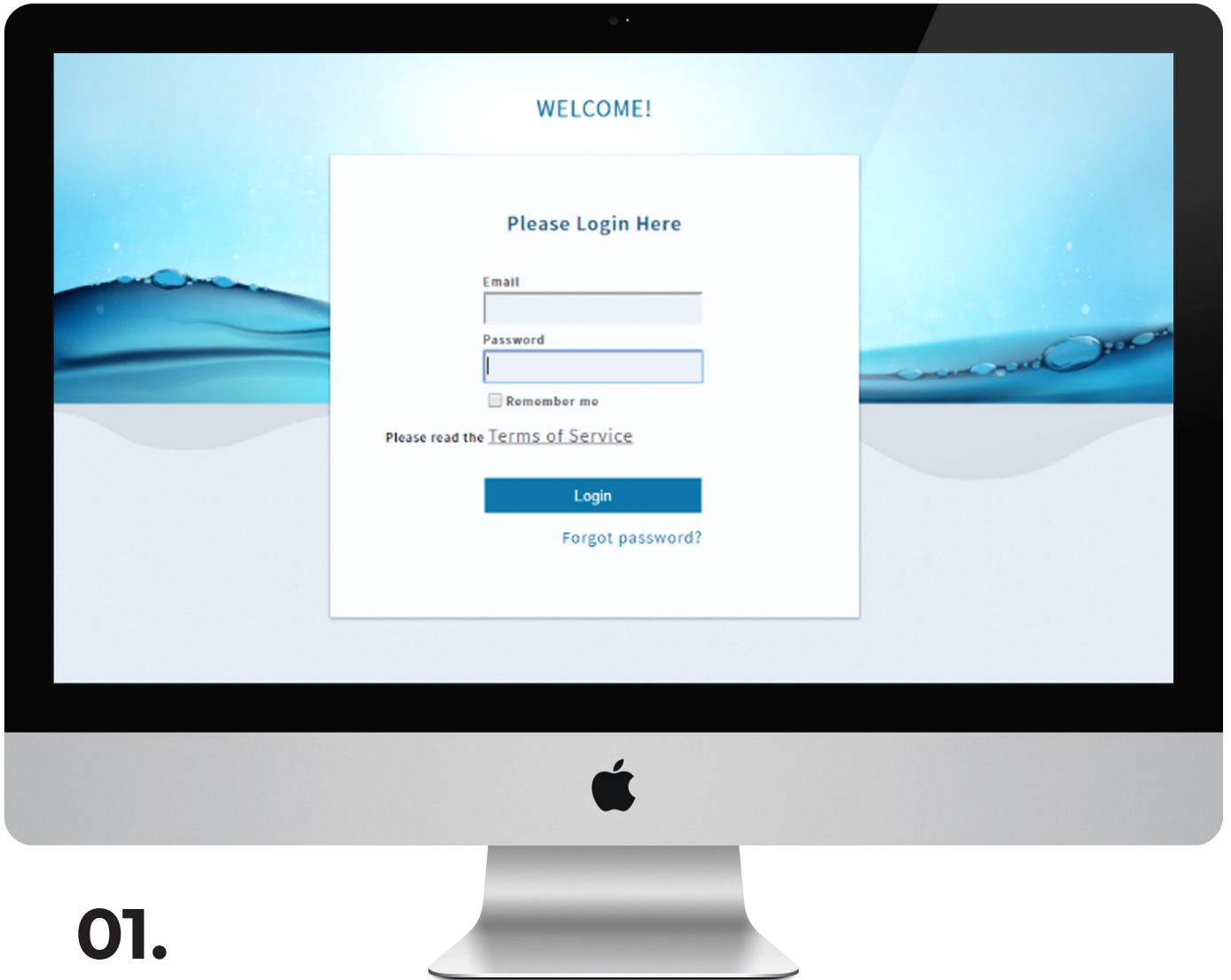

01. Web Portal Login

<https://controlmyspa.com>

Login & Password

- Go to <https://controlmyspa.com> on a computer or tablet web browser. You can also use a phone web browser, but works best on a computer or tablet
- Google Chrome browser is recommended, but works with most other browser

ControlMySpa™

Spa Owner Overview

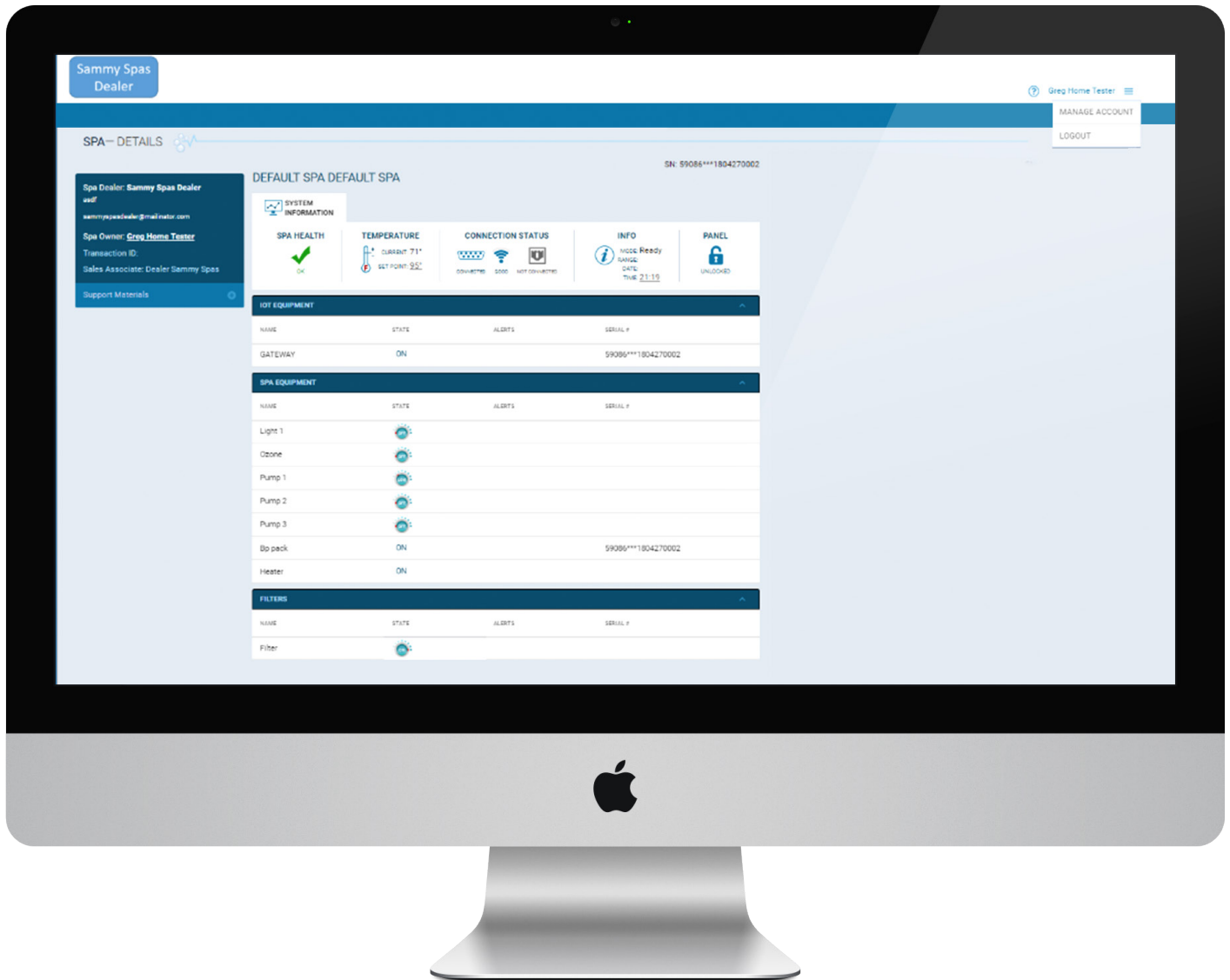

SPA VIEW PAGE

The Information Menu

CONTROLMYSPA™ SUPPORT

Trademark | Patent Notices

The iPhone®, iOS®, iPod® and iPad® are a registered trademark of Apple Inc. The iPhone®, iOS®, iPod® touch and iPad® are a trademark of Apple Inc., registered in the U.S. and other countries.

©Samsung Telecommunications America, LLC (“Samsung”). Samsung, Galaxy S, Super AMOLED, and AllShare are all trademarks of Samsung Electronics Co., Ltd. and/or its related entities. Other company names, product names and marks mentioned herein are the property of their respective owners and may be trademarks or registered trademarks. Appearance of device may vary.

Wi-Fi®, the Wi-Fi CERTIFIED logo, and the Wi-Fi logo are registered trademarks of the Wi-Fi Alliance.

Google, Google Play and other marks are trademarks of Google, Inc.

CMS, ControlMySpa™, BALBOA WATER GROUP and the stylized logo are registered trademarks or applications applied for in the US Patent & Trademark Office. All rights reserved. All other product or service names are the property of their respective owners.

Products are covered under one of more

of the following US Patents: 5332944, 5361215, 5550753, 5559720, 5,883,459, 6282370, 6590188, 7030343, 7, 417, 834 B2 & Canadian Pt 2342614 plus others. Other patents both foreign and domestic applied for and pending.

Compatibility

Apple iOS

The iOS® app version requires iOS 9.0 or later. Compatible with iPhone, iPad, and iPod touch.

Android

Requires Android 4.0 and up

INTELLECTUAL PROPERTY ADVISEMENT

All Intellectual property, as defined below, owned by or which is otherwise the property of Balboa Water Group or its respective suppliers relating to the Balboa Water Group BP Spa Control Systems, including but not limited to, accessories, parts, or software relating to the “System”, is proprietary to Balboa Water Group and protected under federal laws, state laws, and international treaty provisions. Intellectual Property includes, but is not limited to, inventions (patentable or unpatentable), patents, trade secrets, copyrights, software, computer programs, and related documen-

tation, and other works of authorship. You may not infringe or otherwise violate the rights secured by the Intellectual Property. Moreover, you agree that you will not (and will not attempt to) modify, prepare derivative works of, reverse engineer, decompile, disassemble, or otherwise attempt to create source code from the software. No title to or ownership in the Intellectual Property is transferred to you. All applicable rights of the Intellectual Property shall remain with Balboa Water Group and its suppliers.



ControlMySpa™

✉ Email

info@balboawater.com

☎ Phone

P : + 714.384.0384
Customer Service is available:

M — T 7:30AM to 7:00PM
F — 7:30AM to 5:00PM PT

📍 Corporate Office

Balboa Water Group
1382 Bell Avenue
Tustin, CA 92780

MEXICO OPERATIONS

Balboa Water Group
Aguila Azteca 6011
Baja Maq. El Aquila
Mexico 22221

EUROPEAN OPERATIONS

Balboa Water Group
Hydroair International
ApS Roustvej 50 DK-6800
Varde